

# IDA-X

Sugar and sugarfree  
coating



---

AUTOMATIC SUGAR  
COATING INSTALLATION:  
THE PERFECT COMBINATION  
OF DESIGN AND KNOW-HOW  
FOR THE BEST  
QUALITY PRODUCTS

IMPROVED PRODUCTIVITY,  
FLEXIBILITY AND CONSISTANCY  
WITH LOWER LABOUR AND  
ENERGY COSTS

**Dumoulin**





---

# IDA-X

FULL AUTOMATIC  
COATING  
INSTALLATION  
FOR SUGAR  
AND SUGARFREE  
COATING

# IDA-X

FULL AUTOMATIC  
INSTALLATION FOR  
SUGAR AND SUGARFREE  
COATING

Machine type	502X	1002X	2002X	3002X
Useful volume (liters)	650	1300	2600	3900
Batch size (kg)	250-500	500-1000	1000-2000	2000-3000
Drum diameter (mm)	1600	1600	1800	1900
Drum length (mm)	1600	2900	4200	5600
Bed depth (mm)	450	450	540	630

## PRODUCTS RANGE

### A wide range of centers

- Dried fruits, seeds, nuts...
- Toffees, caramels, liquorices...
- Biscuits, extruded products
- Chewing gums and chewy candies

### A wide range of coatings

- Any type of syrup, sucrose, dextrose
- All polyols
- Dry powders, icing sugar...
- Waxing, glazing, varnishing



## DRUM DESIGN

### Fully perforated drum

- Suitable for hard sugar coat, sugarless coat, glazing or varnishing
- Air flow through products bed
- Low pressure drop for better efficiency
- Faster drying time



### Shallow bed depth

- Elongated drum shape for lower bed depth
- Careful handling of fragile products
- Better mixing
- Better exposure to ventilation and spraying

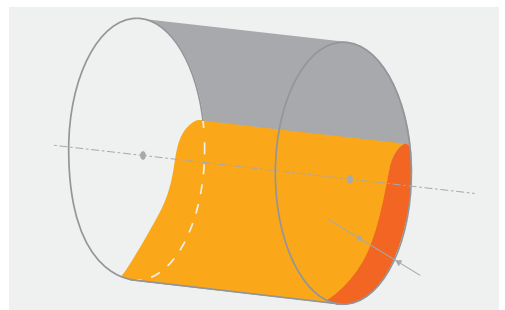

## SYRUP SPRAYING

### Syrup preparation

- Modular custom design
- Hot or cold solutions with various ingredients, gum, gelatine, starch, colour, flavour...

### Syrup dosing and spraying

- High accuracy and consistency, with lobes pump and flowmeter
- Double jacketed networks
- Spraybar extraction for easy maintenance
- Spray nozzles automatic cleaning

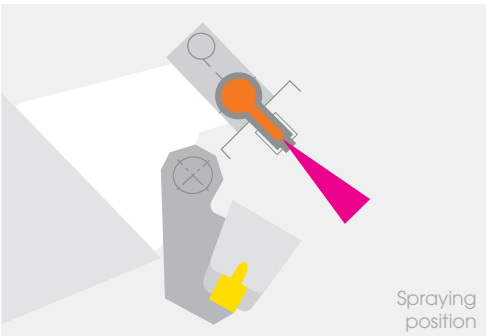
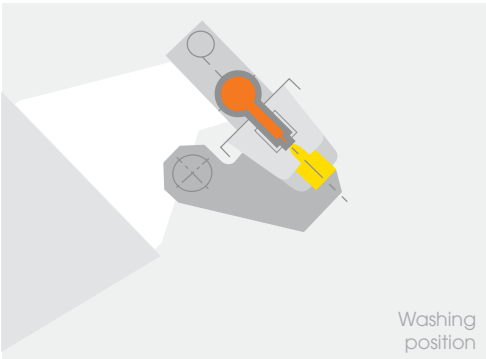

## POWDER DISTRIBUTION

### To help crystallization

for coating with polyols

### To cover products

with cocoa powder, icing sugar...

### Accurate system

with powder dosing / weighing and compressed air powder transport

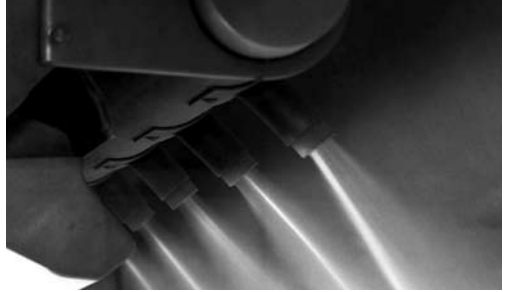
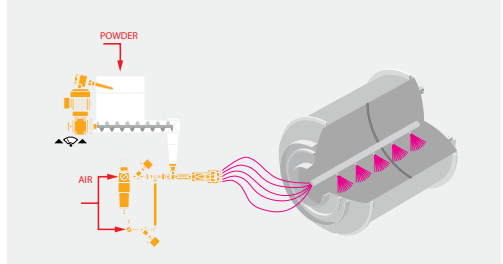

## VARNISHING AND WAXING

### Varnishing solution tanks

For aqueous and alcoholic solution

### Varnish dosing systems

for controlled steps

### Varnish spraying systems in the pan

with airless spray guns

### Micronised carnauba wax distribution

with air spray system



## AIR TREATMENT GROUP

### Process Air

- Airflow, temperature and humidity control
- Perfect repeatability

### Exhaust Air

- Negative pressure inside pan
- Automatic cleaning
- Dust collection

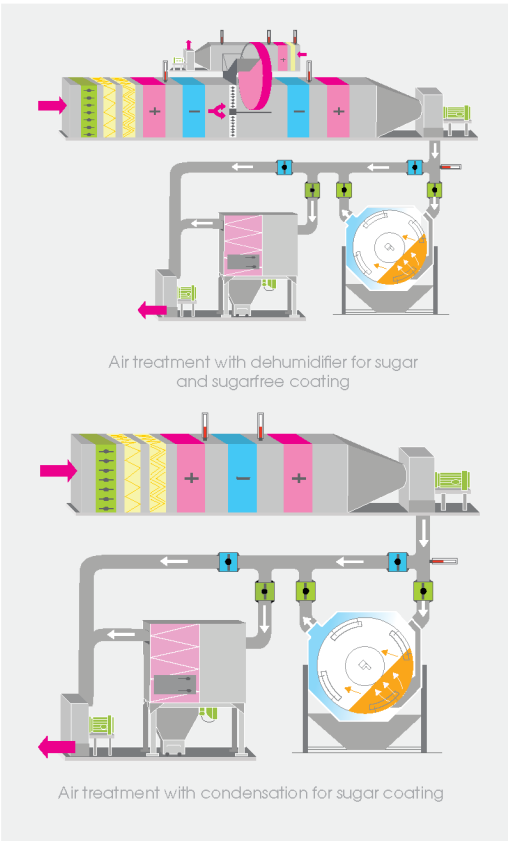

## LOADING SYSTEM

### Custom design solutions

- According to products fragility
- Adapted to batch size and facility layout
- Wide range of dosing conveyors, elevators, belts

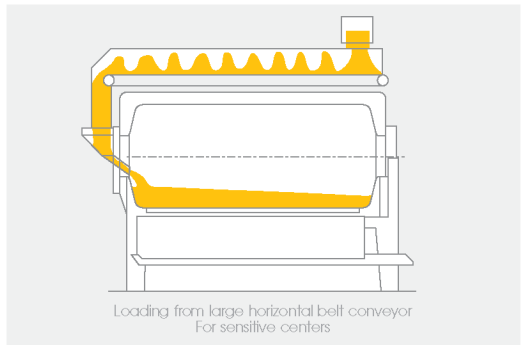
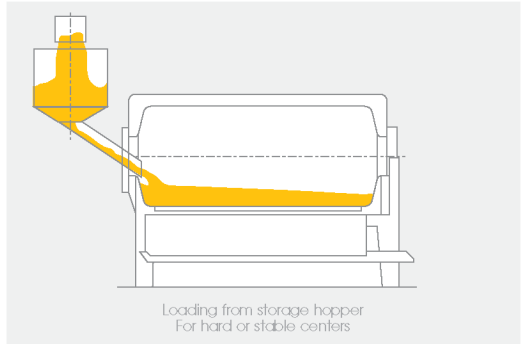

- Automatic fast loading system



## UNLOADING SYSTEM

**Fast unloading system by traps** allowing to start next batch very quickly

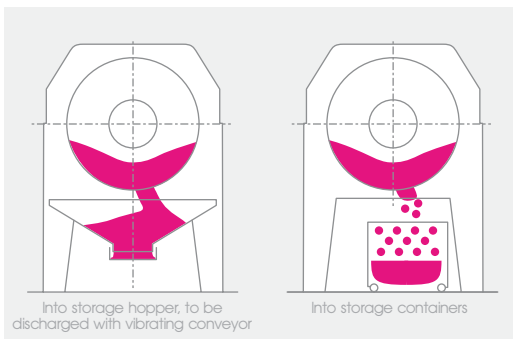

## DEVELOPMENT AND ASSISTANCE

### Industrial scale laboratory

Equipped with 250kg and 500kg coating machines  
Recipe development with your products

### On-site assistance

Operators and maintenance staff training  
Process development and improvement



## AUTOMATION

**Effective control of the coating process**  
with different possibilities

### IDA PROG3

The basic solution for quality coatings with simple machine handling

- Automatic coating cycle according to programmed recipes.
- Semi automatic controls for loading, unloading and washing functions.

### IDA PROG4

Fully automated system allowing to customize all machine parameters

- Automatic coating cycle according to user-friendly recipe building module
- All functions run from operator terminal including programmable sequences
- Overview screens for installation status
- Possibility to network with other machines and supervision system

### IDA PROG5

The ultimate process, production and quality control. Supervisory Control and Data Acquisition (SCADA)

- Batch data recording and displaying
- Historical trends and fault reports
- Recipes download to IDA coaters
- Real-time overview of networked coaters



# Dumoulin

Z.I. Le Closeau  
5, rue Auguste Perdonnet  
77220 Tournan-en-brie - FRANCE  
Tél.: +33-(0)1 64 84 50 00  
FAX : +33-(0)1 64 84 50 01

www.dumoulin.fr  
E-mail : info@dumoulin.fr  
RCS MELUN 582 045 852

大中华区总代理



上海桂禾食品科技顾问有限公司

沪办：上海市 200081 虹口区 四平路 311 号甲座 1008 室  
电话：+86-21-5556 0509 传真：+86-21-5515 0220  
台办：桃园市 330 吉昌街一号四楼  
电话：+886-3-220 3350 传真：+886-3-220 4337  
电邮：greatkhan@seed.net.tw robert.pai@vip.163.com  
网址：www.greatkhan.com info@web.greatkhan.com